

From Pandemic Response to Multi disciplinary Collaboration

A hands-on approach to impactful design



slido



**What connects you to
LearningSCAPES? I'm a...**

ⓘ Start presenting to display the poll results on this slide.

WHAT IS IN
THE UNBOXY
KIT?

what is in the Unboxy Kit

An Unboxy Kit will give you 29 cardboard panels with various components.

Each box contains 2 kits.

Each kit is sufficient for a typical class to actively participate.

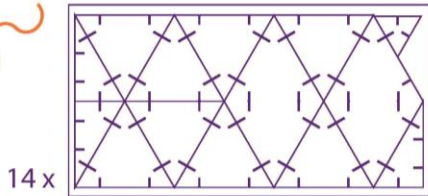
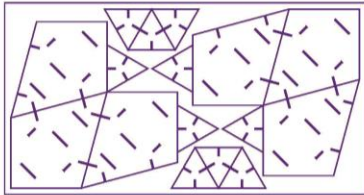
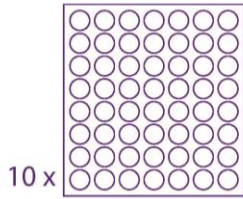
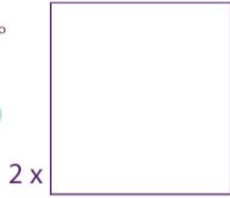

○ 560 x
Circle
Connectors

△ 44 x
Small Triangle

△ 42 x
Half Triangle/
Battresses

△ 112 x
Large Triangle

◇ 18 x
Kite Shaped
Base Plate

◇ 28 x
Diamond

KIT OF PARTS

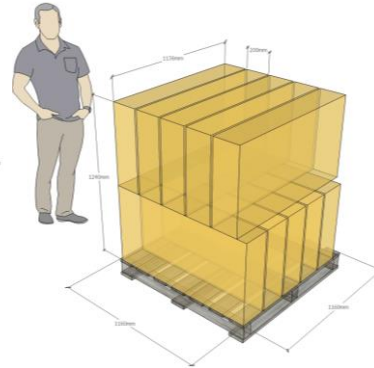
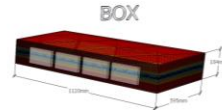
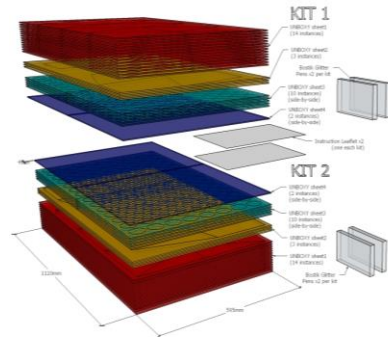

Design Thinking Process Diagram*

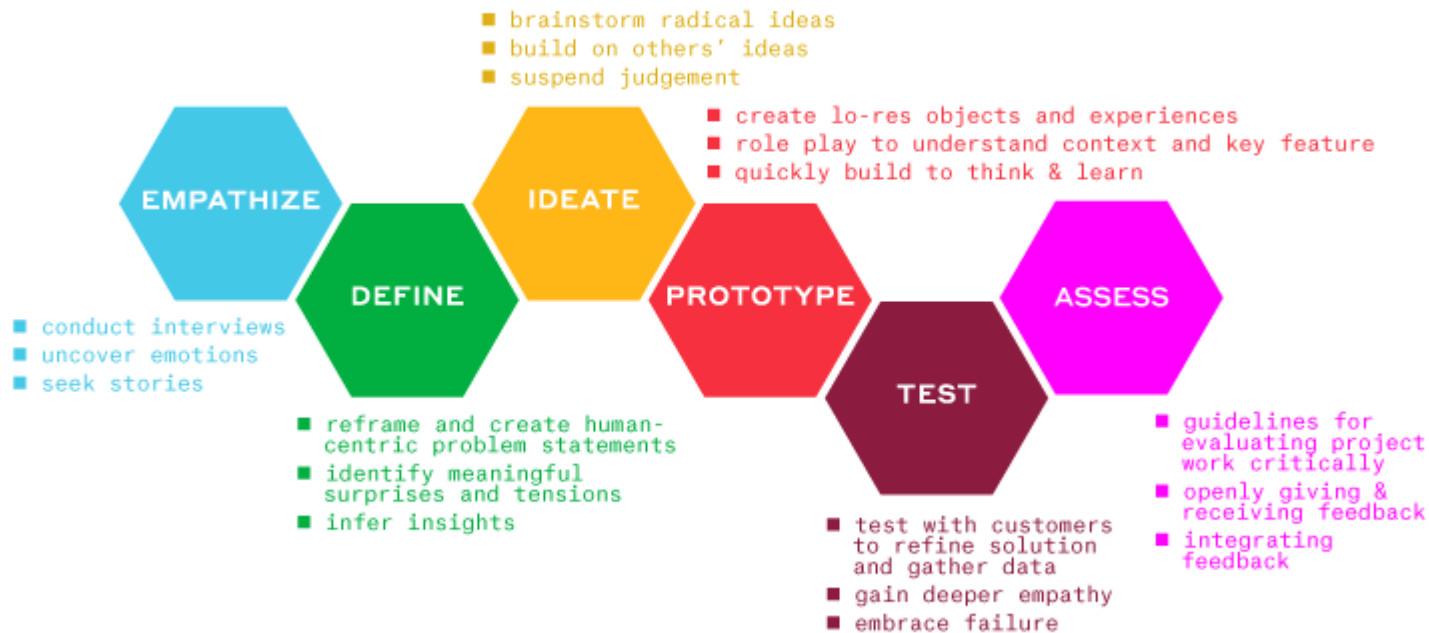



#MASKUP

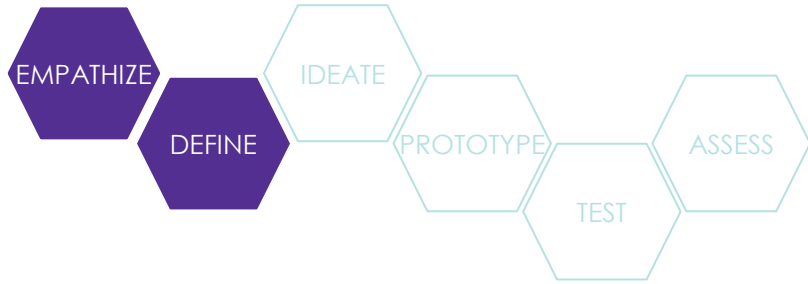

EMPATHIZE & DEFINE

'Children are particularly vulnerable to the challenges of effectively coping throughout a state of disaster'.

(Sprang & Silman, 2013)



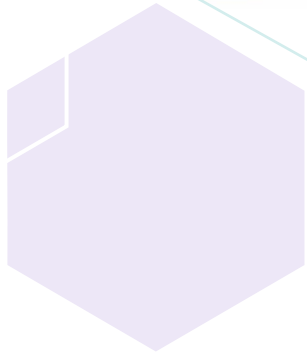
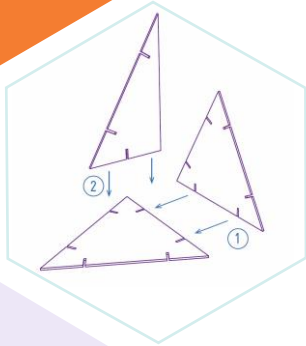

TRANSMISSIVE LEARNING MODEL

POSITIVES

- SET GOALS / OUTCOMES
- DATA DRIVEN – QUANTATIVE APPROACH
- FACTS BASED
- DEFINABLE ANSWERS
- REPLICABLE

NEGATIVES

- PRESCRIPTIVE / CLOSED ENDED
- AUTHORITARIAN
- DIRECTIVE, SEEKING COMPLIANCE



RESEARCH FINDINGS

SAFETY

The theme of safety is understood as the possibility to create secure environments within the materiality of the classroom.

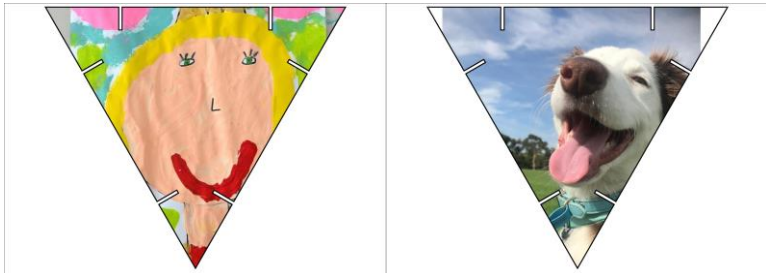

ACTIVITY 1

PASSIVE LEARNING

BUILDING PRESCRIBED SHAPES

WORKSHEETS

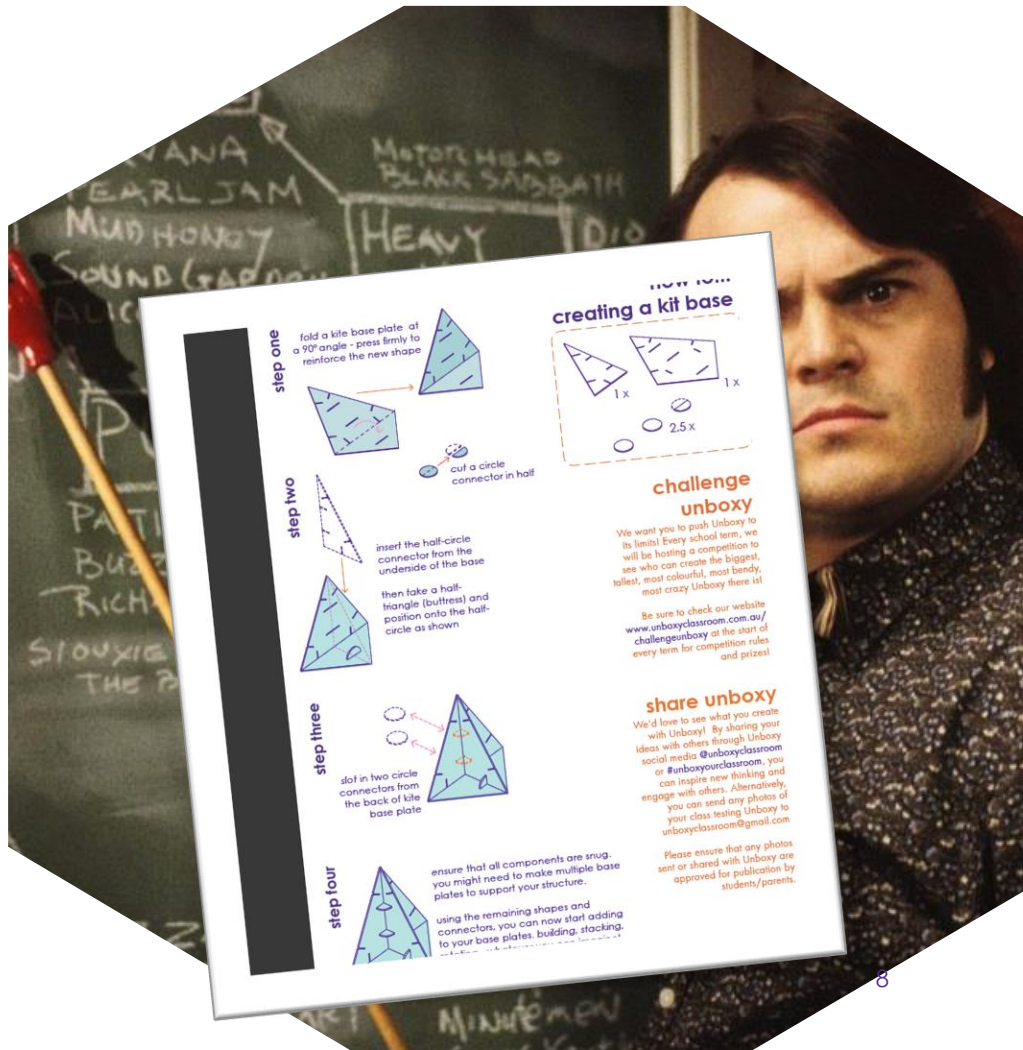

step one

fold a kite base plate at a 90° angle - press firmly to reinforce the new shape

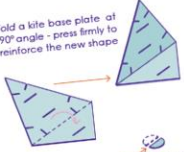

step two

insert the half-circle connector from the underside of the base

then take a half-triangle (buttress) and position onto the half-circle as shown

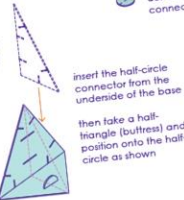

step three

slot in two circle connectors from the back of kite base plate

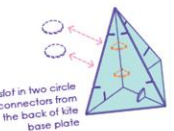

step four

ensure that all components are snug. you might need to make multiple base plates to support your structure.

using the remaining shapes and connectors, you can now start adding to your base plates. building, stacking.

how to create a kit base

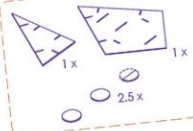

challenge unboxy

We want you to push Unboxy to its limit! Every school term, we will be hosting a competition to see who can create the biggest, tallest, most colourful, most bendy, most crazy Unboxy there is!

Be sure to check our website www.unboxyclassroom.com.au/challengeunboxy at the start of every term for competition rules and prizes!

share unboxy

We'd love to see what you create with Unboxy! By sharing your ideas with others through Unboxy social media @unboxyclassroom or #unboxyourclassroom, you can inspire new thinking and engage with others. Alternatively, you can send any photos of your class testing Unboxy to unboxyclassroom@gmail.com

Please ensure that any photos sent or shared with Unboxy are approved for publication by students/parents.

Unboxy Worksheet - Task 1

Within your group (table) form pairs. Each pair is to produce two of the following shapes. Work with the rest of the group to ensure all shapes are created.



Shape 1 - Half triangles, full triangles



Shape 2



Shape 3



Unboxy Worksheet - Task 1

Within your group (table) form pairs. Each pair is to produce two of the following shapes. Work with the rest of the group to ensure all shapes are created.



Shape 4



Shape 5

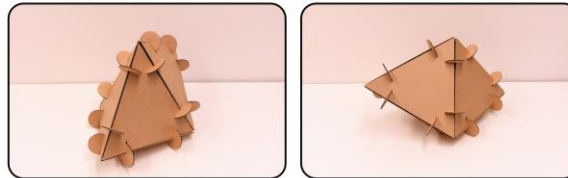

Shape 6



Unboxy Worksheet - Task 1

Within your group (table) form pairs. Each pair is to produce two of the following shapes. Work with the rest of the group to ensure all shapes are created.



Shape 7



Shape 8

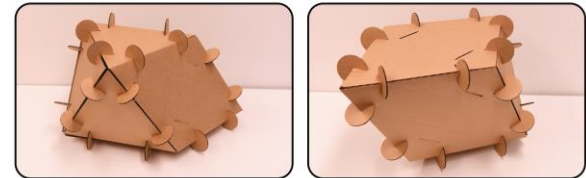

Shape 9



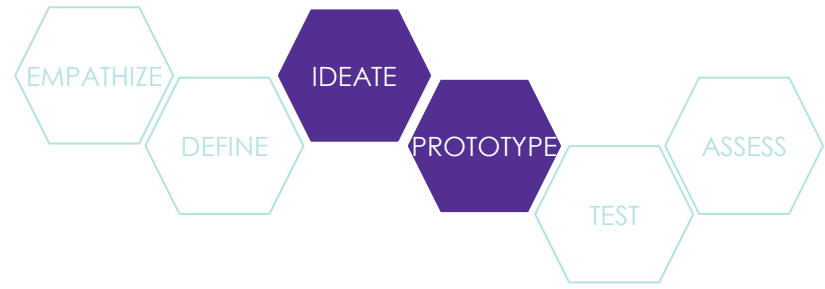

IDEATE & PROTOTYPE



EARLY DESIGN THOUGHT & PROCESS

MULTI DISCIPLINARY APPROACH

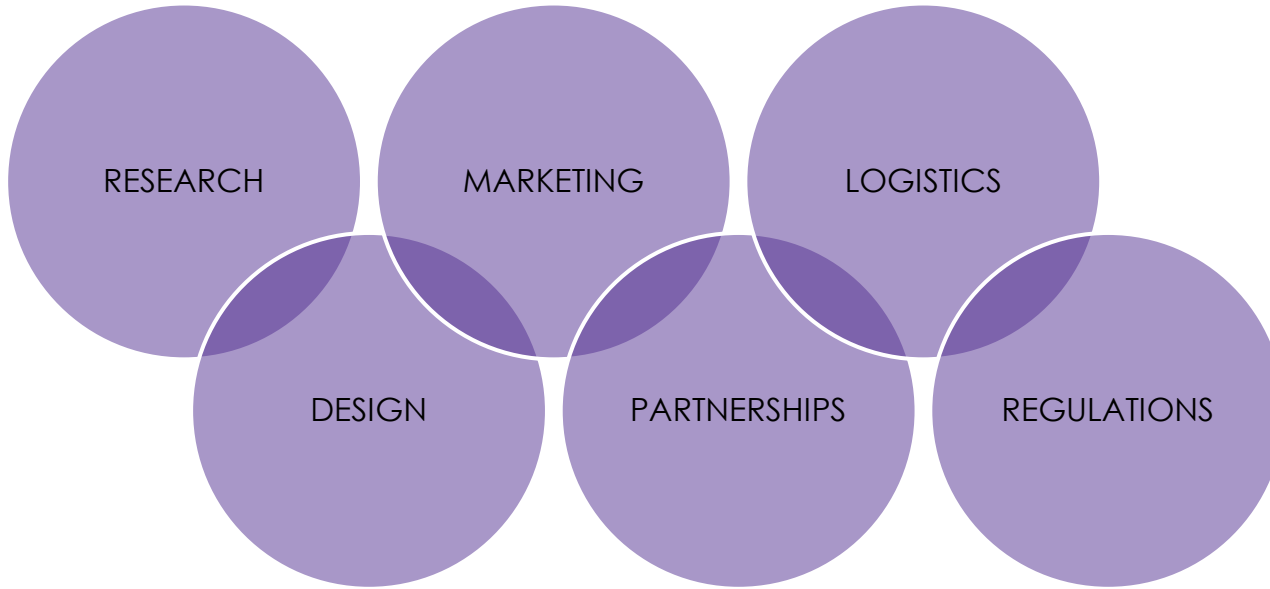
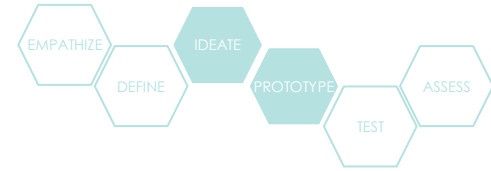

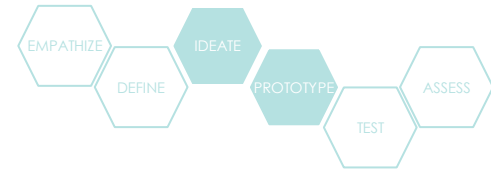

DESIGN CHALLENGES

REMOTE COLLABORATION

COMMUNICATION ACROSS ORGANISATIONS

PRODUCT + DELIVERY COST

CREATING FICTION

EFFICIENT USE OF MATERIAL

KEEPING IT SIMPLE

DETERMINING MANUFACTURING METHOD

DIGITAL PROTOTYPING (VS PHYSICAL)



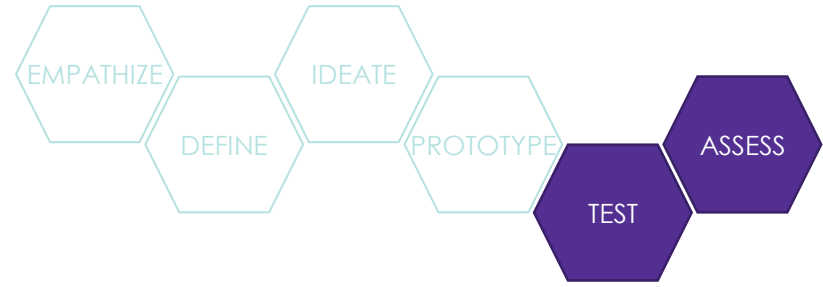

TEST & ASSESS



AMBASSADOR + SCHOOL CHALLENGES

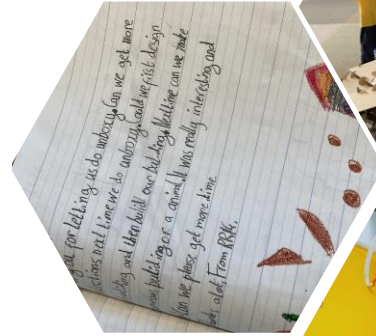
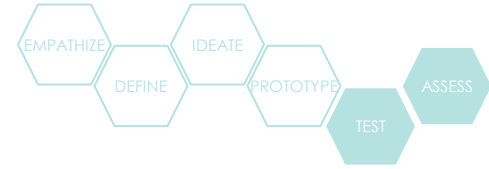

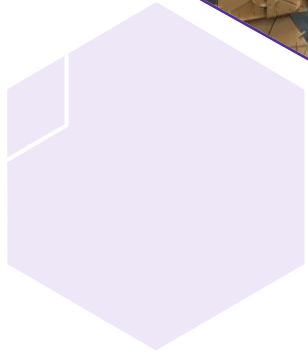
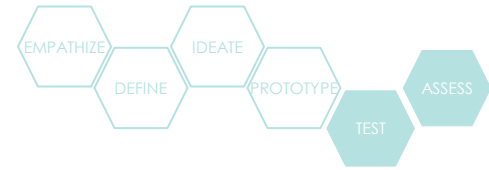

ACTIVE LEARNING MODEL

WITHIN MAINSTREAM AND SPECIAL NEEDS SETTINGS

POSITIVES

- BREAK FROM STRUCTURED LEARNING
- HEALTH AND WELLBEING
- TOOL FOR LEARNING/ENGAGEMENT
- OPEN ENDED
- 'PROBLEM POSING' MODEL
- EXPLORATIVE
- DEMOCRATIC

NEGATIVES

- LOOSELY DEFINED GOALS / OUTCOMES
- NO 'CORRECT' ANSWER
- TIME CONSUMING
- LESS CONTROL FROM EDUCATOR
- COULD LEAD TO MISCONCEPTIONS



RESEARCH FINDINGS ENACTMENT AND EXPRESSION

The enactment theme is understood as the process of acting something out. Through acting and re-enacting children can actively engage in their own meaning making.

The theme of expression is defined as the interpretation and expression of an (in this case unpleasant) event through material representation.



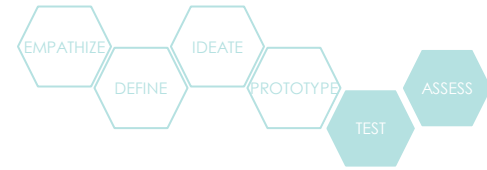

ACTIVE LEARNING WITH REFLECTION

OUR FINISHED 'UNBOXY CHRISTMAS TREE'. THIS PHOTO ALSO INCLUDES OUR ORIGINAL PROTOTYPE (SMALLER) WHICH COULD ALSO BE USED. THIS WAS THE FIRST CONSTRUCTION IN OUR DESIGN PROCESS.



ACTIVITY 2

ACTIVE LEARNING EXERCISE

BUILDING A FLOWER USING PRESCRIBED
SHAPES / OTHER



ACTIVITY 2

criteria for building a flower

- Your flower must have a stem, at least one leaf and two flowers
- And be as tall as you can make it



slido



Out of all the subjects at school, where does Unboxy fit?

ⓘ Start presenting to display the poll results on this slide.

slido



What are the benefits of Unboxy for Active Learning?

ⓘ Start presenting to display the poll results on this slide.

slido



**How did the Unboxy
activity make you feel?**

ⓘ Start presenting to display the poll results on this slide.

Thank You

Matt Dwyer

matt@y2architecture.com.au

